

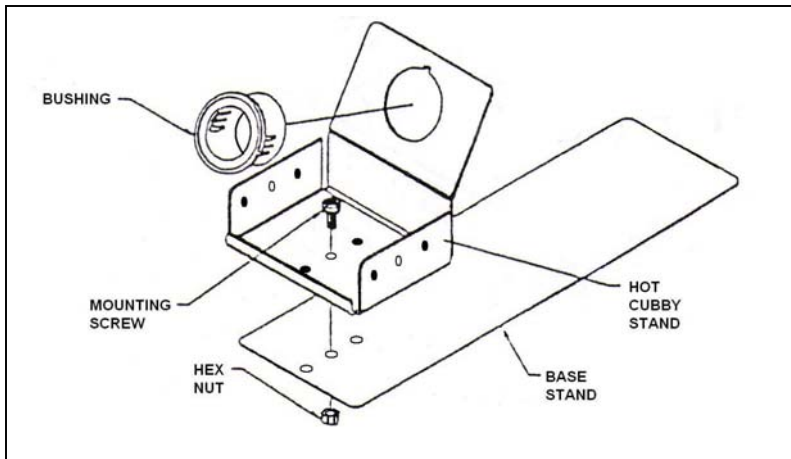

**ASSEMBLY AND INSTALLATION INSTRUCTIONS
FOR PASTE DISPENSER CUBBY KIT
PACE PART NUMBER 6019-0038
MANUAL NUMBER 5050-0314 REV. A**

The following instructions provide the user with the information necessary to assemble and install the PACE Paste Dispenser Cubby (P/N 6019-0314). Perform the following procedure step by step, in sequence, to obtain proper results:

1. Check the enclosed parts with the parts list (Table 1) to insure that you have all the required parts.
2. If 10cc or smaller barrels are to be used in the paste dispense operation, insert the bushing into the Hot Cubby Stand as shown. The Bushing will snap in place.
3. Attach the Hot Cubby Stand to the Base Stand as shown using one Mounting Screw and Hex Nut. Tighten Mounting screw to secure in place.



DESCRIPTION	QUANTITY	PART NUMBER
Hot Cubby Stand	1	1257-0126
Base Stand	1	1257-0173
Mounting Screw	2	1405-0398-02
Hex Nut	2	1410-0088
Bushing	1	1251-0076

Table 1. Parts List

Figure 1. Assembling Paste Dispenser Cubby

4. Attach the Paste Dispenser Cubby to the left side of the power source chassis using the procedure below:

- a) At the left rear of the power source, insert a Hex Nut into the top “T” slot on the left side of the chassis.
- b) Insert a Mounting Screw through the mounting hole indicated on the Paste Dispenser Cubby.
- c) Place the Paste Dispenser Cubby in position on the left side of the power source.
- d) Attach Mounting Screw to Hex Nut (installed in T slot).
- e) Slide Paste Dispenser into position as desired. Tighten Mounting Screw to secure in place.

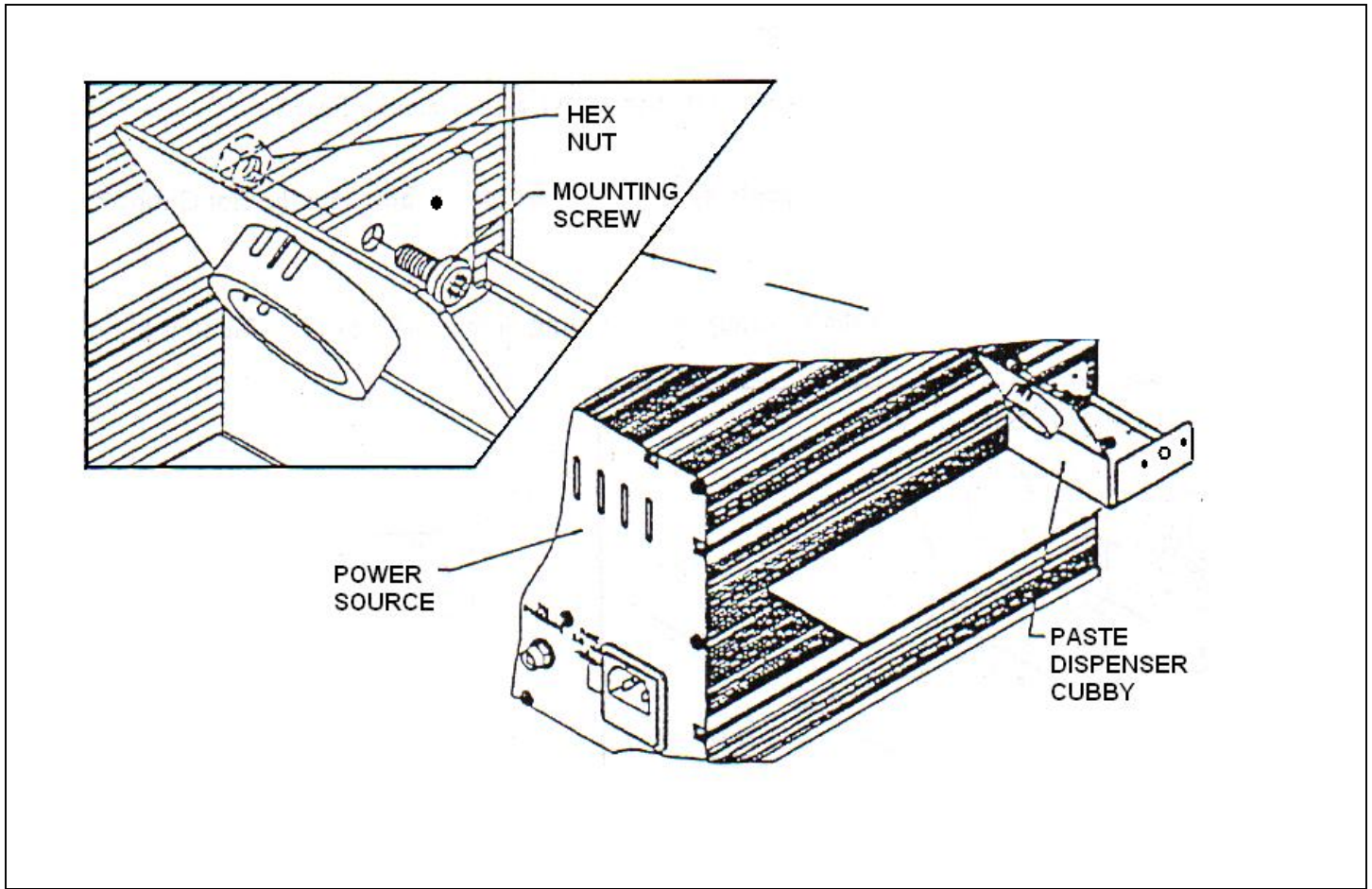

Figure 2. Attaching Paste Dispenser Cubby To Power Source

PACE Incorporated retains the right to make changes to specifications contained herein at any time, without notice. Contact your local authorized PACE Distributor or PACE Incorporated to obtain the latest specifications.

The following are trademarks and/or service marks of PACE, Incorporated, MD, USA:

INSTACAL™, FUMEFLO™, HEATWISE™, PACEWORLDWIDE™, PERMAGROUND™, POWERPORT™, POWERMODULE™, TEMPWISE™, TIP-BRITE™, AUTO-OFF™, and TEKLINK™.

The following are registered trademarks and/or service marks of PACE Incorporated, Annapolis Junction Maryland U.S.A.

ARM-EVAC®, FLO-D-SODR®, MINIWAVE®, PACE®, SENSATEMP®, SNAP-VAC®, SODRTEK®, SODR-X-TRACTOR®, ST 325®, THERMOJET®, THERMOTWEEZ®, VISIFILTER®, THERMO-DRIVE®, and TOOLNET®.

PACE products meet or exceed all applicable military and civilian EOS/ESD, temperature stability and other specifications including MIL STD 2000, ANSI/JSTD 001, IPC7711, and IPC A-610.

Additional copies of this manual or other PACE literature may be obtained from:



PACE Incorporated
 9030 Junction Drive
 Annapolis Junction,
 MD 20701
 Tel: (301) 490-9860
 Fax: (301) 498-3252

PACE Europe Limited
 13 Tanners Drive
 Blakelands
 Milton Keynes
 Tel: (44) 1908-277666
 Fax: (44) 1908-277777