



**ANGLE BRACKET KIT
INSTALLATION INSTRUCTIONS
PACE PART NUMBER 6018-0097
MANUAL NUMBER 5050-0425 REV. B**

The Angle Bracket Kit elevates the front of the power source to allow easier viewing and access to the front panel controls. Attach the kit to your power source using the following instructions. Also, if you have purchased a PRC 1500 or PRC 1500E system, a second kit is included; attach the second kit to the PPS 85 (or PPS 85E power source).

1. Turn the power source upside down on the work bench with the front panel facing away from you.
2. Position Angle Bracket to the front of the power source and just behind the two (2) rubber feet on the power source case.
3. From the rear of the power source, insert the 2 enclosed Mounting Screws (head first) into the two (2) "T" Slots on the bottom of the power source case. Pull the screws toward the front of the power source.

NOTE

The ThermoFlo Source will have 2 Thumb Nuts and Mounting Screws already attached to the bottom of the case

4. Install a Thumb Nut onto the end of each Mounting Screw.
5. Slide the 2 (two) Mounting Screws forward through the two (2) Mounting Slots in the bracket.
6. Tighten Thumb Nuts to secure bracket in position.
7. Place the two (2) rubber feet in position on the Angle Bracket as shown in the illustration. The feet should be placed at the ends of the bracket as shown.

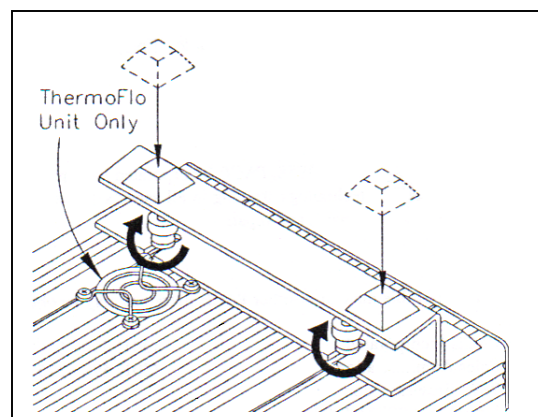
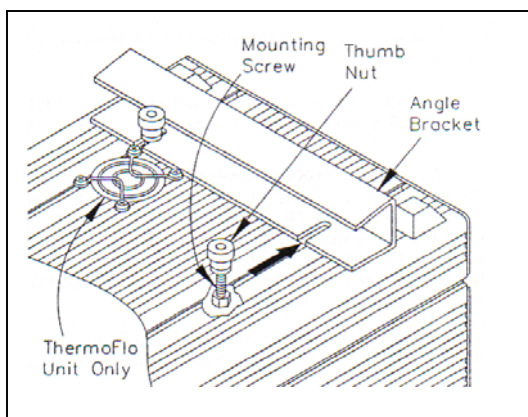

PACE Incorporated
9030 Junction Drive
Annapolis Junction,
MD 20701
Tel: (301) 490-9860
Fax: (301) 498-3252

PACE Europe Limited
13 Tanners Drive
Blakelands
Milton Keynes
Tel: (44) 1908-277666
Fax: (44) 1908-277777