

SX-100 / SX-90 Sodr-X-Tractor

SX-100 / SX-90 Replacement Parts

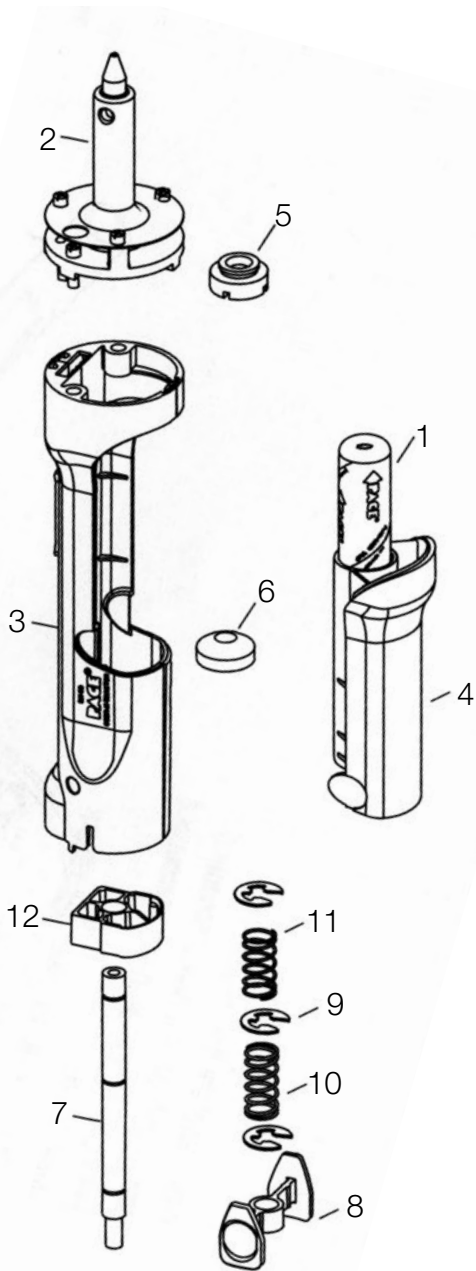

Item	Description	Part Number
	SX-100/SX-90 SensaTemp Handpiece	6010-0106-P1
	SX-100/SX-90 SensaTemp Kit (includes Handpiece, Tip & Tool Stand & Tip Tool)	6993-0213-P1
	SX-100/SX-90 Handpiece IntelliHeat	6010-0149-P1
	SX-100/SX-90 Handpiece Kit IntelliHeat	6993-0266-P1
	SX-100/SX-90 Tip & Tool Stand	6019-0060-P1
	FLUX/SODR TRAP (Package of 10)	1309-0054-P10
	FLUX/SODR TRAP (Package of 100)	1309-0054-P100
	SX-100/SX-90 Heater Assembly (Black Connector also fits SX-80)	6010-0107-P1
	SX-100/SX-90 Heater Assembly (Blue Connector only fits SX-100/SX-90's that come with Blue Connector heater)	6010-0163 -P1
	Handle Assembly (Includes the Switch, PCB, and Cord Assembly) SensaTemp	6010-0115-P1
	Handle Assembly (Includes the Switch, PCB, and Cord Assembly IntelliHeat)	6010-0162-P1
	Door Assembly	1119-0141-P1
	Front Seal	1213-0087-P1
	Front Seal	1213-0087-P10
	Front Seal	1213-0087-P25
	Rear Seal	1213-0086-P1
	Plunger Shaft	1261-0154-P1
	Plunger Lock	1500-0063-P1
	"C" Clips (3 pieces)	1348-0387-P3
	Spring "Long Side"	1221-0136-P1
	Spring "Short Side"	1221-0137-P1
	Door Lock	1119-0142-P1
	VisiFilter, Fixed	1309-0020-P1
	VisiFilter, Replacement	1309-0028-P1
	Replaceable VisiFilter Elements	
	Package of 10	1309-0027-P10
	Package of 25	1309-0027-P25
	Package of 50	1309-0027-P50
	Tube, 1370mm (54") Length, black	1342-0015-08-P1
	Hose Clamps	1321-0085-01-P6
	Hose Fitting, Female (Quick Disconnect)	1259-0086-P1
	Hose Fitting, Male (Quick Disconnect)	1259-0087-P1
	Tube, Silicon, 2" Length	1342-0001-01-P1
	Heater Set Screws	1348-0547-P10
	Button	1500-0064-P1
	Heat Sleeve Kit	6993-0229-P1
	Heat Sleeve Clip	1211-0064-P1
	Glass Flux Solder Trap Kit	6000-0212-P1
	Z-Baffle (for Glass Chamber)	4010-0115-P2
	Glass Chamber	1265-0011-P1
	Sodr-X-Tractor Filters for Glass Chamber	
	Package of 10	1309-0018-P10
	Package of 50	1309-0018-P50
	SX Tool Stand	6019-0082-P1
	Replacement Sponge for New Tool Stand	4021-0013-P3
	Replacement Brass Tip Cleaner for New Tool Stand	1129-0018-P1
	Heater MTG Screws	1405-0534-P3
	Desoldering Tip Cleaning Tool	6993-0200-P1
	Flux Trap Cubby Kit	6993-0230-P1
	Tip Tool	1100-0206-P1



SX-100 / SX-90 Desoldering Tips



Tips Selection:

One of the most important aspects for successful solder removal is the selection of the proper size tip. There are several points to keep in mind.

- 1 The Inside Diameter (I.D.) of the tip must be large enough to fit over the lead, while providing sufficient room so that air and solder can be drawn through the tip.
- 2 The Outside Diameter (O.D.) of the tip must be slightly smaller than the diameter of the pad to prevent tip contact to the board laminate and minimize the possibility of damage.

For the SX-100 / SX-90 - 3/16" Shank Diameter

Tips	Description	Diameter	SX-100/SX-90 P/N*	Endura P/N**	
	Thermo-Drive	0.76mm (0.030") I.D. X 2.03mm (0.080") O.D.	1121-0930-P5	1121-0625-P5	
	Thermo-Drive	1.02mm (0.040") I.D. X 2.29mm (0.090") O.D.	1121-0931-P5	1121-0624-P5	
	Thermo-Drive	1.52mm (0.060") I.D. X 3.05mm (0.120") O.D.	1121-0932-P5	1121-0626-P5	
	Thermo-Drive	2.29mm (0.090") I.D. X 5.1mm (0.200") O.D.	1121-0933-P5	1121-0627-P5	
	Thermo-Drive	4mm (0.16") I.D. X 5.1mm (0.200") O.D.	1121-0951-P5		
 	Thermo-Drive, Flathead	1.27mm (0.050") x 2.28mm (0.090") I.D. x 2.79mm (0.110") x 4.82mm (0.190") O.D.	1121-0934-P5	1121-0821-P5	
	Extended Reach Thermo-Drive	0.78mm (0.030") I.D. X 2.29mm (0.090") O.D.	1121-0935-P5	1121-0628-P5	
	Extended Reach Thermo-Drive	1.02mm (0.040") I.D. X 2.54mm (0.10") O.D.	1121-0936-P5	1121-0629-P5	
	Extended Reach Thermo-Drive	1.52mm (0.060") I.D. X 3.05mm (0.120") O.D.	1121-0937-P5	1121-0630-P5	
	ThermoMax	0.76mm (0.030") I.D. X 1.91mm (0.075") O.D.	1121-0938-P5	1121-0882-P5	
	ThermoMax	1.02mm (0.040") I.D. X 2.20mm (0.085") O.D.	1121-0939-P5	1121-0883-P5	
	ThermoMax	1.52mm (0.060") I.D. X 2.69mm (0.106") O.D.	1121-0940-P5	1121-0884-P5	
		Precision	0.50mm (0.020") I.D. X 1.79mm (0.070") O.D.	1121-0941-P5	1121-0680-P5
		Precision	0.76mm (0.030") I.D. X 2.03mm (0.080") O.D.	1121-0942-P5	1121-0678-P5
Precision		1.02mm (0.040") I.D. X 2.29mm (0.090") O.D.	1121-0943-P5	1121-0679-P5	
Precision		1.52mm (0.060") I.D. X 2.79mm (0.110") O.D.	1121-0944-P5	1121-0690-P5	
Precision		0.635mm (0.025") I.D X 1.39mm (0.055") O.D.	1121-0949-P5		
Precision		0.635mm (0.025") I.D X 1.14mm (0.045") O.D.	1121-0950-P5		
 	Flo-D-Sodr	1.52mm (0.060") I.D. X 4.78mm (0.188") O.D.	1121-0945-P5	1121-0631-P5	
	Flo-D-Sodr, Precision	0.50mm (0.020") I.D. X 1.78mm (0.070") O.D.	1121-0946-P5	1121-0681-P5	
	Flo-D-Sodr, Precision	0.76mm (0.030") I.D. X 2.03mm (0.080") O.D.	1121-0947-P5	1121-0682-P5	
	Flo-D-Sodr, Precision	1.02mm (0.040") I.D. X 2.29mm (0.090") O.D.	1121-0948-P5	1121-0683-P5	

*SX-100//SX-90 tips can only be used with SX-100/SX-90 heaters date code 10-06 or later. **Endura tips should only be used in the SX-70/80.

SX-100 Surface Mount Removal Pik-Tips

Tips	Description	Tip Size A X B	Part Number
	TSOP-32	8.1mm (0.320") x 12.7mm (0.500")	1121-0566-P1
	TSOP-28	8.1mm (0.320") x 19.3mm (0.760")	1121-0567-P1
	TSOP-40	9.9mm (0.390") x 19.3mm (0.760")	1121-0568-P1
	TSOP-56	14.2mm (0.560") x 19.3 mm (0.760")	1121-0569-P1
	TQFP-28	8.2mm (0.322") x 8.23mm (0.3220")	1121-0571-P1
	TQFP-32	8.7mm (0.344") x 8.7mm (0.344")	1121-0572-P1
	TQFP-52	12mm (0.472") x 12mm (0.472")	1121-0573-P1
	TQFP-40	12mm (0.472") x 12mm (0.472")	1121-0574-P1
	TQFP-80	13.2mm (0.520") x 13.2mm (0.520")	1121-0575-P1
	TQFP-80/100	15.3mm (0.604") x 15.3mm (0.604")	1121-0576-P1
	PQFP-80/100	16.8mm (0.660") x 22.9mm (0.900")	1121-0603-P1
	TQFP-144	21.6mm (0.850") x 21.6mm (0.850")	1121-0604-P1
	TQFP-112	22.1mm (0.870") x 22.3mm (0.870")	1121-0605-P1