



PROPERTY OF
ENGINEERING SERVICES

DO NOT REMOVE

OPERATION AND MAINTENANCE
INSTRUCTIONS FOR THE

PRC CONSOLE SERIES

Repair Systems

MODELS

PRC351
PRC351E

PRC 750A
PRC750AE

PRC1000A
PRC1000AE

MANUAL NO. 5050-0159

Rev. C

GENERAL INFORMATION

Before using your PACE PRC Console Series Repair System, read the following instructions and procedures to become familiar with its proper operation and maintenance.

Table of Contents

Title	Page
General Information	2
Panel Identification	4
Functional Accessories and Work Aids	6
Set-up	9
Operation	10
Maintenance	12
Replacement Parts	14

INTRODUCTION

The PACE PRC351/750A/1000A models are programmable repair systems with a unique expansion capability that can be varied to meet the changing conditions in today's modern electronics.

- PACE PRC351 — consists of power source, conductive work surface and selected accessories.
- PACE PRC351E — export version of PRC351
- PACE PRC750A — consists of power source, console and selected accessories.
- PACE PRC750AE — export version of PRC750A.
- PACE PRC1000A — consists of power source, console, pedestal and selected accessories.
- PACE PRC1000AE — export version of PRC1000A.

SPECIFICATIONS

• General Characteristics:

- a. variable air pressure and flow control
- b. dual switch control Foot Pedal
- c. Foot Pedal control (three position)
- d. heavy-duty electrical output power control

• Power Requirements

- PRC351 — 120VAC, 50-60Hz, 750W
- PRC351E — 220VAC, 50Hz, 750W
- PRC750A — 120VAC, 50-60Hz, 750W
- PRC750AE — 220VAC, 50Hz, 750W
- PRC1000A — 120VAC, 50-60Hz, 750W
- PRC1000AE — 220VAC, 50Hz, 750W

• Variable Air Pressure:

- 0.05 psi to 12.0 psi

• Physical Parameters:

PRC351/E

- 20"W x 7½"H x 30"L
- (51cm W x 19cm H x 76cm L)
- 41 lbs. 8 oz. (18.8 kg)

PRC750A/AE

- 20"W x 12½"H x 30"L
- (51cm W x 32cm H x 76cm L)
- 44 lbs. 10 oz. (20.2 kg)

PRC1000A/AE

- 20"W x 45½"H x 30"L
- (51cm W x 125.5cm H x 76cm L)
- 118 lbs. 2 oz. (53.6 kg)

CAPABILITIES

All capabilities are dependent upon the use of the proper Functional Accessories or Work Aids (refer to Functional Accessories and Work Aids section). The systems capabilities are as follows:

- controlled desoldering
- abrade, mill, drill, grind and cut
- removal of conformal coatings
- high strength reflow solder
- accurate component forming
- conductive and resistive heating for safe removal of components
- repair damaged plated-thru holes/terminals
- replating damaged or worn connectors or contacts

GENERAL INFORMATION

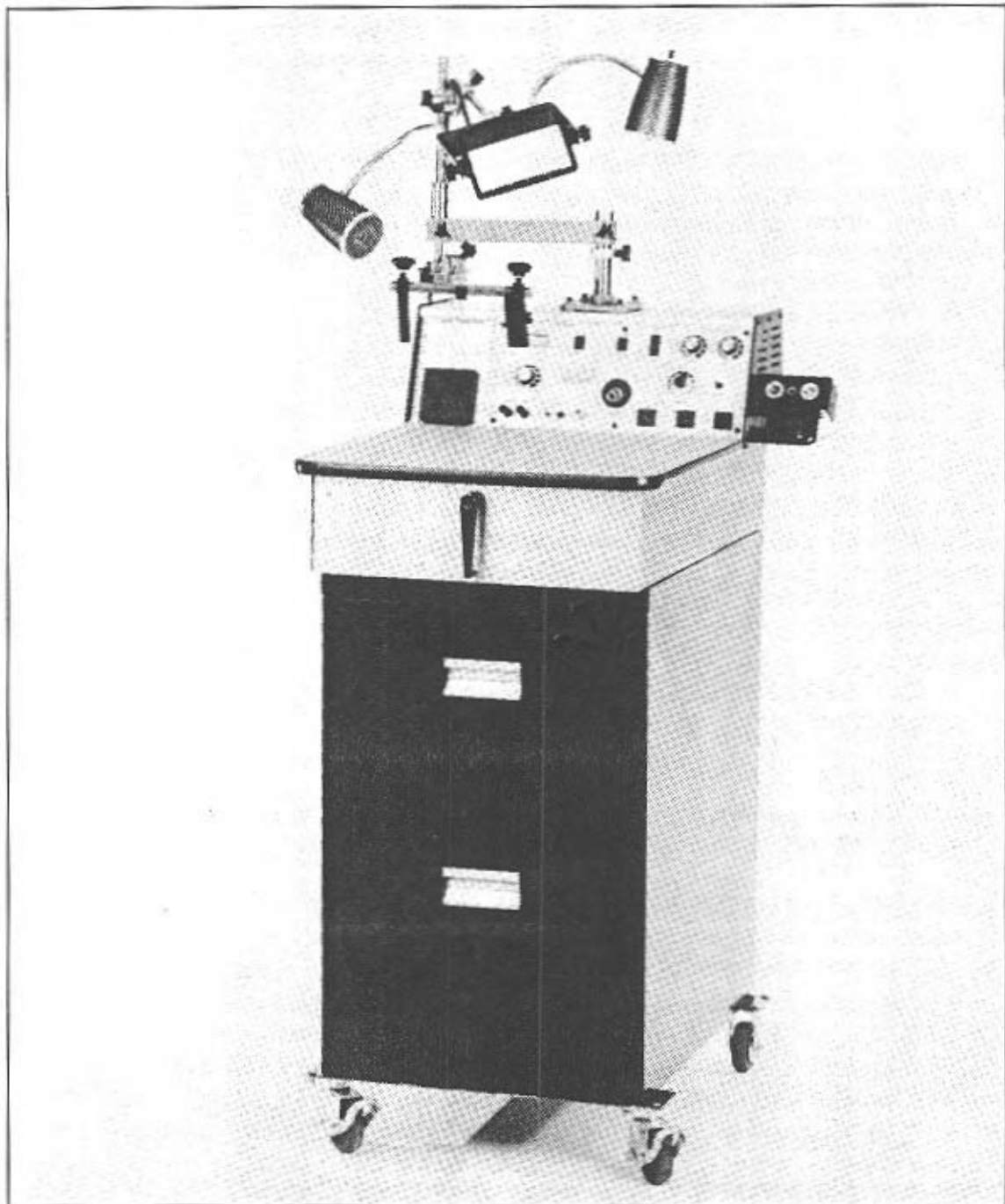

FIGURE 1. PACE REPAIR SYSTEM PRC351/E, 750A/AE, 1000A/AE

GENERAL INFORMATION

PARTS IDENTIFICATION:

Table 1 and Figure 2 refers to identification and location of each part required for the operation of the PACE PRC351/E, 750A/AE and PRC1000A/AE.

TABLE 1. PANEL IDENTIFICATION OF PRC351/750A/1000A POWER SOURCE

- ELECTRO-PULSE INDICATOR—indicates power to Heat Pulse AC and Plate Pulse DC Outputs.
- ELECTRICAL/MECHANICAL CONTROL SWITCH—provides electrical/mechanical and mechanical/electrical sequence to Foot Pedal.
- MOTOR/PUMP SWITCH—provides three (3) operational sequences in conjunction with two (2) position Foot Pedal.
- MAIN POWER SWITCH—controls input power to system.
- VARIABLE HEAT CONTROLS—provides variable heat controls to Heat Control Outputs.
- PRESSURE CONTROL—"quick-connect" variable pressure flow control
- VACUUM FITTING—"quick-connect" vacuum flow for solder removal.
- HOT CUBBY—holder and cleaning station for Functional Accessories.
- HEAT CONTROL OUTPUTS—AC receptacles for Functional Accessories, 3 amp max.
- AC FIXED RECEPTACLE—provides direct AC line voltage for Functional Accessories.
- MINICHINE™ OUTPUT—high torque, low RPM output, "quick-connect" while in idle or running mode.
- GROUND TERMINAL—provides positive ground connection when required.
- PLATE PULSE DC OUTPUTS—electrical output for Plating Cables controlled by Variable Output Control.
- HEAT PULSE AC OUTPUTS—electrical output for Functional Tool Cord controlled by Variable Output Control.
- VARIABLE OUTPUT CONTROL—adjusts output power level to Plate Pulse DC and Heat Pulse AC Outputs.
- CONSOLE—convenient work surface and housing for power source.
- AC RECEPTACLE/FUSE (F1)—receptacle for Main Power Cord with fuse for overload protection to system.
- FOOT PEDAL CONNECTOR—"quick-connect" for Foot Pedal.
- CONDUCTIVE WORK SURFACE—an anti static mat work surface.
- AUX, AC FIXED RECEPTACLE—an auxiliary AC receptacle for Functional Accessories.
- CIRCUIT BREAKER (CB1)—provides overload protection to Variable AC Voltage Controls.
- CIRCUIT BREAKER (CB2)—provides overload protection to Motor.
- CIRCUIT BREAKER (CB3)—provides overload protection to Plate Pulse DC Outputs.
- MAIN POWER LINE CORD—provides main power input to power source.
- FOOT PEDAL—controls, mechanical, pneumatic or primary electrical functions.

Figure 2 identifies the front and rear panel controls and indicators mounted on the PRC351/750A Repair System. (NOTE: The PRC1000A is identical to the PRC351/750A except that it has a pedestal for moving the system around your shop or work area).

GENERAL INFORMATION

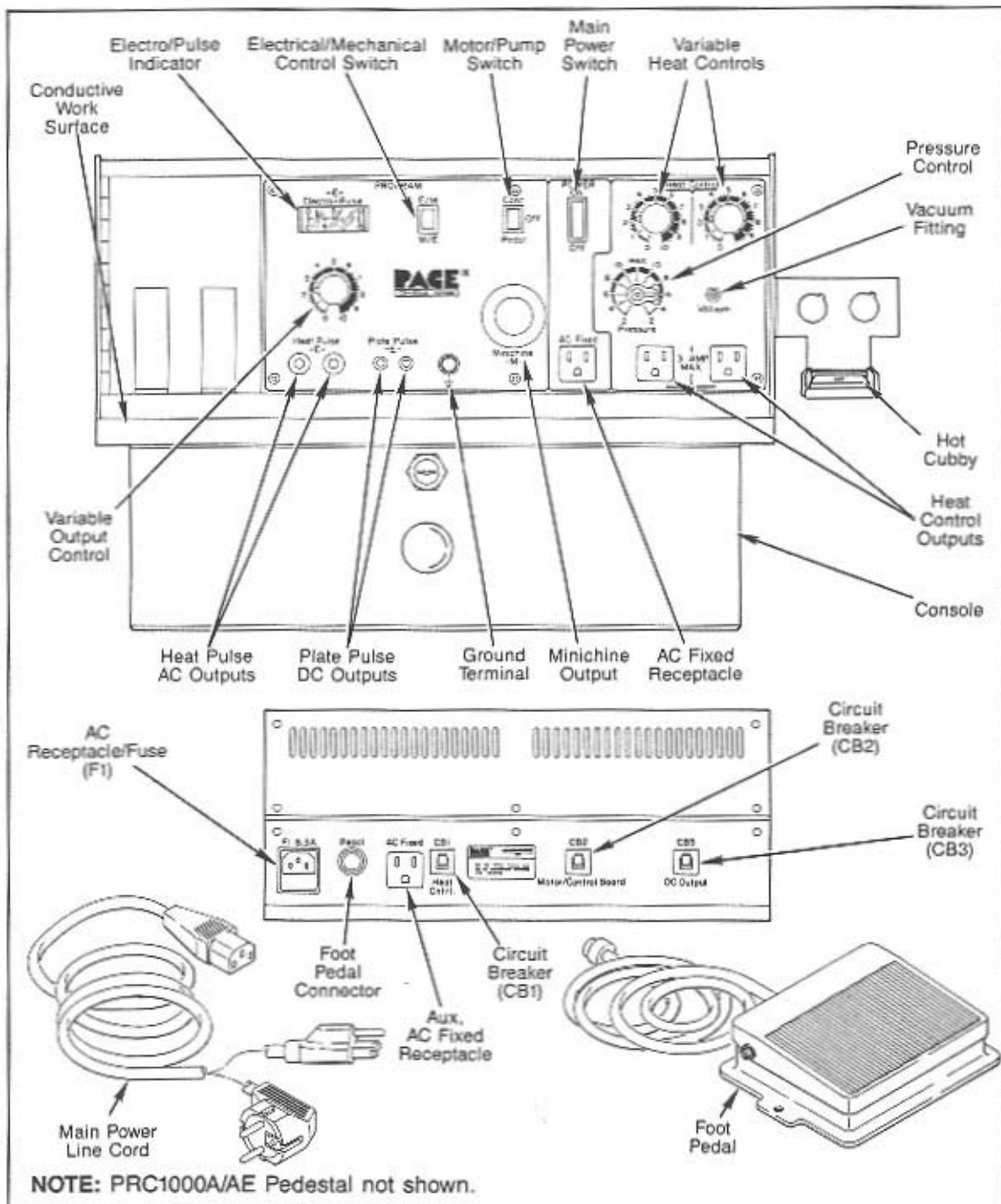
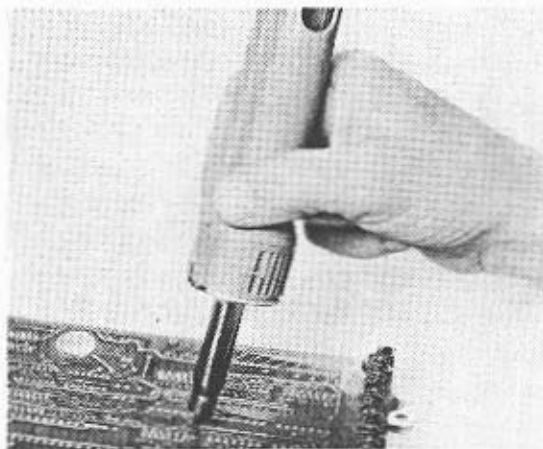

FIGURE 2. PANEL IDENTIFICATION OF PACE PRC351/750A/1000A REPAIR SYSTEM

GENERAL INFORMATION

FUNCTIONAL ACCESSORIES and WORK AIDS

The following information is provided to help you identify the Functional Accessories and Work Aids available and their capabilities. All items shown are optional. Those necessary to perform your rework, repair or modification tasks are normally selected for delivery with the Power Source. The accessories are shown in order of importance to their usage for typical repair work.



1. SODR-X-TRACTOR SYSTEM—Provides the capabilities to melt solder joints and remove via vacuum or pressure.

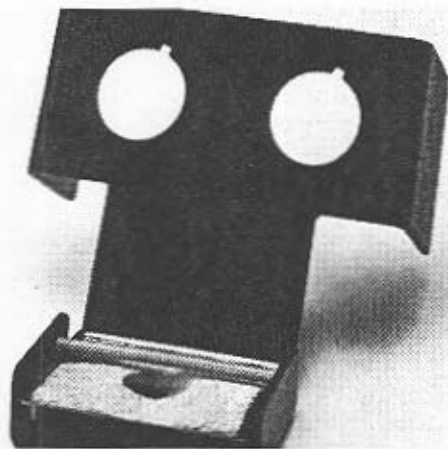

2. SPECIAL AIDS—Includes the Hot Cubby and Cleaning System for storing and cleaning both the SODR-X-TRACTOR and soldering iron; and the Conform I for forming axial lead components and straightening and cutting transistor leads to length.

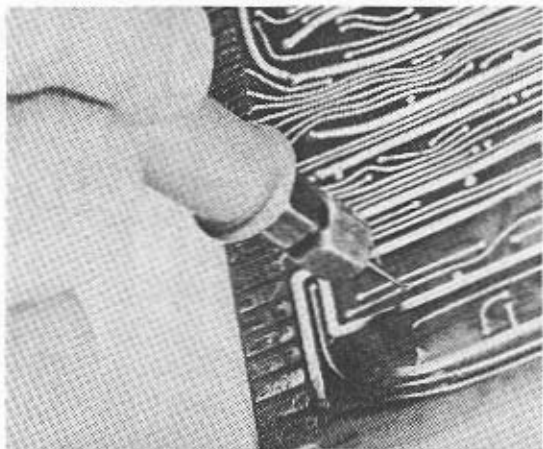

3. MINICHINE™ MINIATURE MACHINING SYSTEM—Provides the capability to drill, mill, abrasive clean, grind and polish various metallic and non-metallic materials.

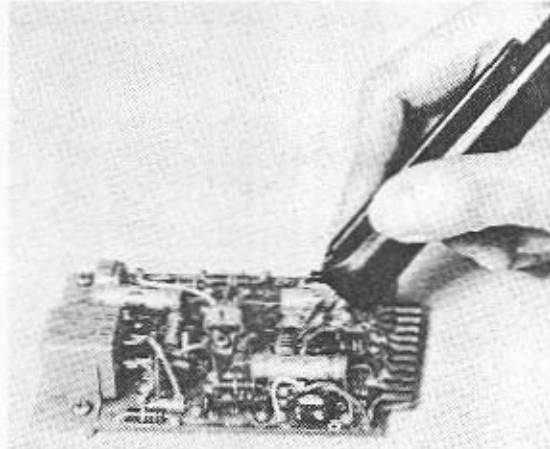

4. THERMOPARTING/LAPFLO SOLDERING SYSTEMS—Thermoparting provides a primary and safe means for removing thick conformal coatings from circuit board assemblies without damage. Lapflo pencil-like unit provides a dependable and safe means of producing reflow soldered joints for flat packs on circuit boards.

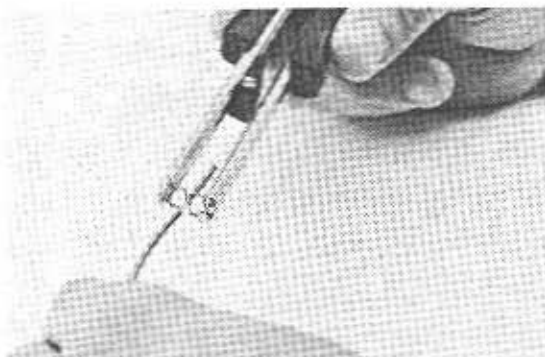

5. **THERMAL STRIP SYSTEM**—Provides capability for stripping wire insulations from 12AWG to 30AWG, solid or stranded wires, without damaging the wire conductor.



6. **RESISTWEEZ RESISTANCE TWEEZERS**—Provides capability to solder very closely spaced pins, terminals and lugs, as found in connectors and small parts.

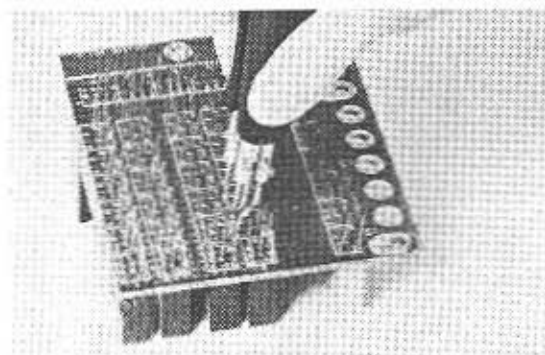

7. **CONDUCTWEEZ HEATING TWEEZERS**—Pulse-type tweezer heating system is used for soldering and desoldering closely spaced, limited access areas where pulsed conductive heating is desired to prevent stray currents which could damage components.

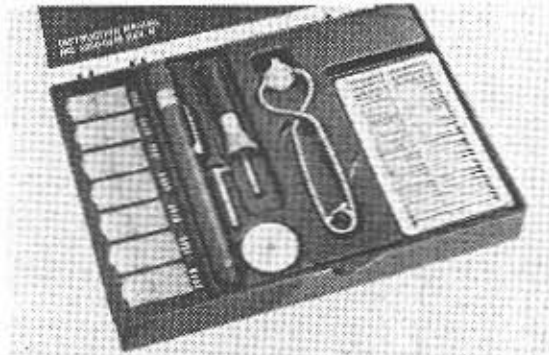

8. **CIRKIT SELECTOR PACK**—Includes everything needed to repair and/or replace lifted, damaged or missing pads or conductors on printed circuit boards.



9. **SWAPLATING SYSTEM**—Self-contained, easy to use electro-plating system for rapid, controlled replating of connectors, contacts, wave guides, etc. Solutions available for electro cleaning plus tin, lead, copper, nickel and gold plating.

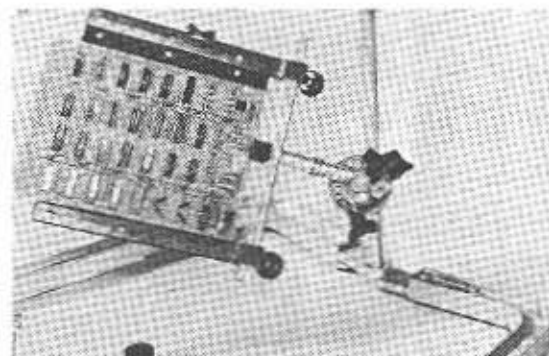

10. **WORK HANDLING AND POSITIONING SYSTEM**—Provides the holding and positioning of modules, chassis, connectors and delicate work.

GENERAL INFORMATION



11. OPTICAL LIGHTING—A large lens with full binocular capability up to 14 inches. Manipulative qualities and balanced lighting arrangement provides infinite adjusting capability. Models available for mounting to upright column of work handling system.

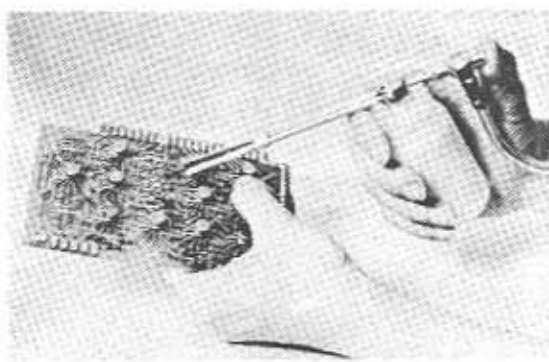

12. SPRAY SYSTEM—Provides ability to spray small areas with fine coatings, solvents, paints, cleaners, etc.

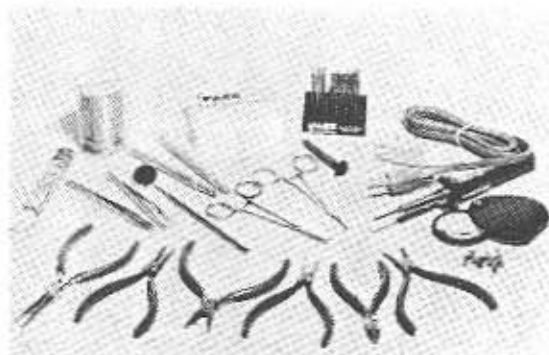

13. HAND TOOLS—A selected variety of hand tools to meet a broad variety of electronic repair problems.

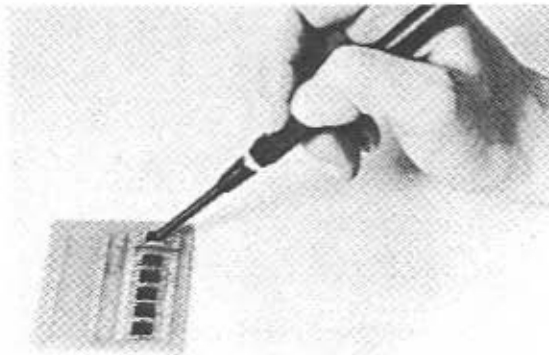

14. VACUUM CLEANING AND HANDLING SYSTEM—Permits the air pressure removal of particles from limited access areas. Vacuum handling of delicate parts can be accomplished.

Additional items available are:

- 15. MATERIALS KIT—Includes solvent, coating material, epoxy and flux in safe individual containers. Provided with devices to meter, mix and apply them.
- 16. ACCESSORY CASE—A convenient case for storage and transportation of Functional Accessories.

SET-UP:

Using Figure 2 in the Panel Identification section, set-up the PRC351, 750A and 1000A power source using the following steps:

IMPORTANT

If you have the PRC1000A, assemble Console to Pedestal per assembly instructions supplied.

- place all switches in the "OFF" or "0" position,
- position the power source on a convenient bench (PRC351/750A only), plug Main Power Line Cord into a three wire grounded outlet. (NOTE: Main power supply receptacle should be polarized, properly grounded and checked before initial equipment operation),
- position the power source in a convenient location (PRC1000A only), plug Main Power Line Cord into a three wire grounded outlet. (NOTE: Main power supply receptacle should be polarized, properly grounded and checked before initial equipment operation),
- attach the Hot Cubby to the power source,
- place the Sodr-X-Tractor and Soldering Iron into the Hot Cubby. Assemble clips to attach Vacuum Hose to AC Power Cord,
- connect the Sodr-X-Tractor AC Power Cord into the right Variable Heat Control Output receptacle and the Soldering Iron to the left Variable Heat Control Output receptacle of the power source, cut a 1"–3" piece from plastic Vacuum Hose, attach one end to the VisiFilter™ and the other end to the Vacuum Fitting on power source,
- attach Sodr-X-Tractor Vacuum Hose to *lettered side* of VisiFilter for solder removal,
- attach Sodr-X-Tractor Vacuum Hose to the Pressure Control for pressure or hot air jet modes,
- adjust the Pressure Control on the power source to "MAX" position for air pressure, and the "MIN" for hot air jet,
- adjust the Variable Heat Controls to setting "10" so that the Sodr-X-Tractor and Soldering Iron will be ready for use,
- position the Foot Pedal for operators convenience and plug into Foot Pedal Connector located on rear of power source. Depress Foot Pedal several times to make sure that you get the feel of the two positions,

ELECTRICAL/MECHANICAL CONTROL SWITCH POSITION	INDICATION
E/M	The first position of the Foot Pedal activates primary electricals. The second position of the Foot Pedal operates <i>only</i> the Motor.
M/E	The Motor is activated in the first position of the Foot Pedal. Full depression of the Foot Pedal activates <i>only</i> the primary electrical outputs.

OPERATION:

The power source is now set-up and ready to place into operation. Perform the following steps to become operable, again using Figure 2 for reference:

- place the Main Power Switch to the "ON" position (switch will illuminate),
- place Motor/Pump Switch to the "PEDAL" position,
- adjust the right Variable Heat Control on the power source to a setting of "8". Allow approximately 10 minutes of warm up time for the Sodr-X-Tractor,
- after the Sodr-X-Tractor has heated up for 10 minutes, adjust the Variable Heat Control for an operating temperature of between 6½-8,
- place Motor/Pump Switch in the "CONT" position. This will provide continuous pressure, vacuum, and mechanical power. The Motor will run continuously until the Motor/Pump Switch is moved to another position.
- place Motor/Pump Switch in the "OFF" position. (**NOTE:** The Motor will not run in this position).

MINICHINE

- place Motor/Pump Switch in the "PEDAL" position,
- insert the Flex Shaft into the Minichine drive output (refer to Figure 3). Tap Foot Pedal to rotate drive for easy engagement. Double detent of Minichine cable provides *ready* and *run* position. (**NOTE:** Rotational power for the Minichine is activated with the Foot Pedal or the Motor/Pump Switch in the "CONT" position).

FUNCTIONAL ACCESSORIES

LOW VOLTAGE AC

- place Motor/Pump Switch in the "OFF" position for AC/DC Low Voltage Outputs. (**NOTE:** No vacuum and/or air pressure is present when the Motor/Pump Switch is in the "OFF" position),
- attach the quick connect Universal Cord to a Functional Accessories Tool (refer to Figure 4). The Universal Cord provides rapid interchange of various Functional Tools and eliminates the need for a separate integral power cord,
- set the Variable Output Control to desired power for the Functional Accessories Tool. Start with lower setting, increase Variable Output Control to desired heat,

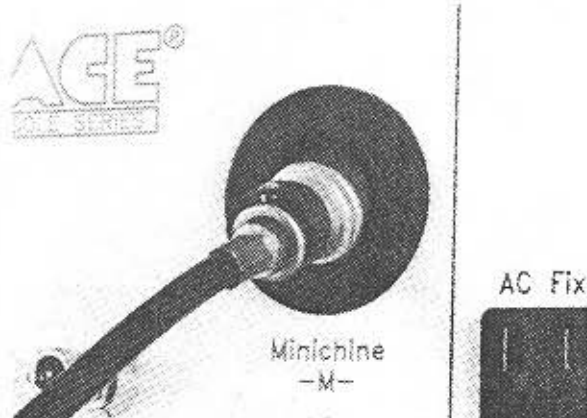

FIGURE 3. MINICHINE CONNECTION



FIGURE 4. UNIVERSAL CORD ATTACHMENT

- attach the Universal Cord to the Heat Pulse AC Outputs (refer to Figure 5),

IMPORTANT

For auxiliary heating operations, set the Motor/Pump Switch to "PEDAL" position, set Electrical/Mechanical Control Switch to "E/M" position. Depress Foot Pedal to first position which activates Low Voltage power.

LOW VOLTAGE DC

- for plating operation, set Motor/Pump Switch to "PEDAL" position. Depress the Foot Pedal and adjust the Variable Output Control to the desired DC voltage for the Plate Pulse,
- attach the Plating Cables to black and red Plate Pulse DC Outputs (refer to Figure 6). (NOTE: For reversed polarity connect red to black and black to red),

IMPORTANT

Turn Variable Output Control to the "OFF" position when work is complete. This will protect your Tools and Tips from heat damage.

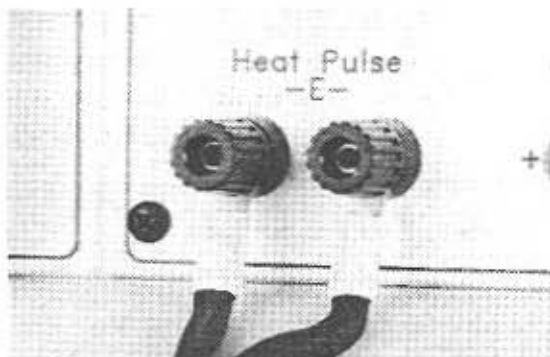

FIGURE 5. UNIVERSAL CORD CONNECTION

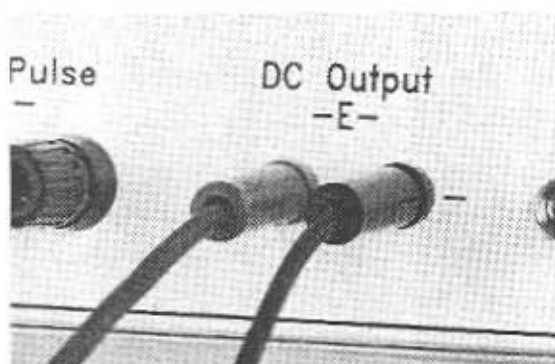

FIGURE 6. PLATING CABLE CONNECTION

Recommended low voltage settings for Functional Accessories are shown in **Table 2. Heat Application Chart**. The settings are approximate and in actual use may be varied for variations in power. It is always best to start with the lower setting and increase the heat in small increments to prevent overheating and damage to the workpiece.

TABLE 2. HEAT APPLICATION CHART

Functional Accessories Tool	Control Setting	Operation
Resistweez	10	Soldering Cup Terminal
		Feedthru capacitor removal
Striptweez	5.5	Wire stripping, vinyl insulation
	8.5	Wire stripping, teflon insulation
Conductweez	8	Soldering light work
Thermopart	5	Foam, poly U removal
	6	Epoxy removal
	7.25	Lifting clinched leads
Lapflo	5.3	Flat pack soldering, standard tip

MAINTENANCE

MAINTENANCE

Maintenance of the PACE PRC351/750A/1000A is minor and relatively easy to perform. For symptoms, conditions and solutions, refer to **Table 3. Corrective Maintenance.**

TABLE 3. CORRECTIVE MAINTENANCE

SYMPTOM	CONDITION	SOLUTION
No power to the system	Blown fuse (F1)	1. Replace 6.3A fuse (F1) located on rear of power source in the AC Receptacle/Fuse (F1).
No power to the Variable Heat Controls	Circuit breaker tripped	1. Reset Heat Control Circuit Breaker (CB1) located on rear of power source.
No power to the Motor/Control Board	Circuit breaker tripped	1. Reset Motor/Control Board Circuit Breaker (CB2) located on rear of power source.
No power to the DC Outputs	Circuit breaker tripped	1. Reset DC Output Circuit Breaker (CB3) located on rear of power source.
General loss of vacuum	Dirty filter(s) or Motor/Pump	1. Check filters weekly and replace monthly. a. Disconnect Main Power Line Cord from power source before opening cover. b. Remove cover screws, let cover swing down. c. Locate Motor/Pump in power source. d. Remove black cap(s) from Motor/Pump muffler assembly (refer to Figure 7). e. Clean and/or replace filter if necessary. 2. Clean Pump Housing, Rotor and Vanes (refer to Figure 8).

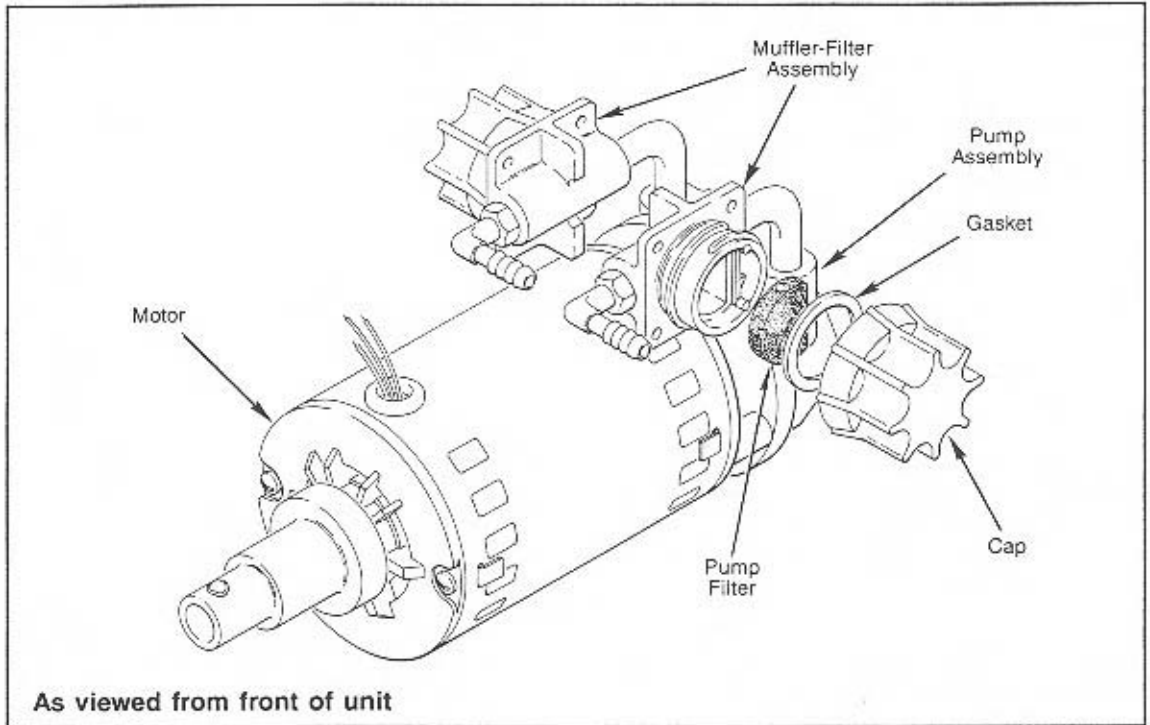

FIGURE 7. LOCATION OF FILTERS ON MOTOR/PUMP ASSEMBLY

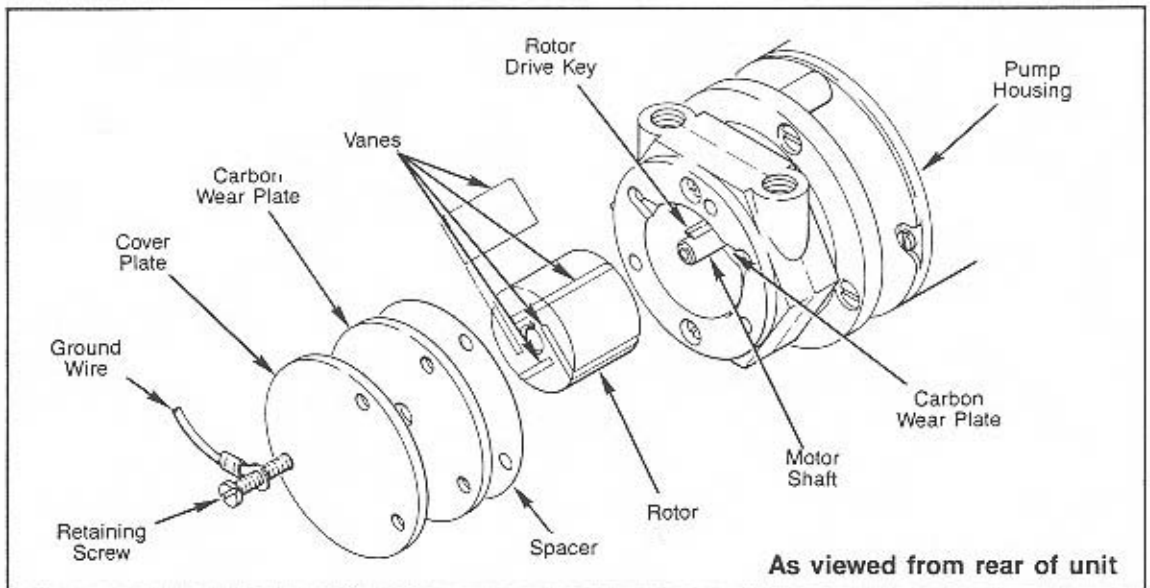

FIGURE 8. PUMP HOUSING ASSEMBLY

REPLACEMENT PARTS

REPLACEMENT PARTS

The chart below is intended as a guide for configuration of your system, power source and equipment.

TABLE 4. SYSTEMS CONFIGURATION

Repair System	Power Source	Console, Power Source w/ (Pedestal 1000A, AE only)	System with Functional Accessories and Work Aids
351	7008-0159	7018-0032	8001-0042
351E	7008-0160	7018-0033	8001-0043
750A	7008-0159	7018-0029	8001-0006
750AE	7008-0160	7018-0031	8001-0021
1000A	7008-0159	7018-0028	8001-0007
1000AE	7008-0160	7018-0030	8001-0023

When ordering replacement parts for your PACE PRC351/E, 750A/AE and 1000A/AE Console Series Repair System, refer to Table 5 and Figure 9 locating the desired part. Use the item number in Figure 9, then refer to Table 5 for that item number, part description and PACE part number.

**TABLE 5. LIST OF REPLACEMENT PARTS COMMON TO
PACE PRC351/E, 750A/AE AND 1000A/AE SYSTEM**
(Refer to Figure 9 for Item Number)

ITEM NO.	DESCRIPTION	PACE PART NUMBER					
		PRC351	PRC750A	PRC1000A	PRC351E	PRC750AE	PRC1000AE
1	PRC Console Series	8001-0042	8001-0006	8001-0007	8001-0043	8001-0021	8001-0023
2	PRC Console & Power Source	7018-0032	7018-0029	7018-0028	7018-0033	7018-0031	7018-0030
3	Work Surface Table	1143-0006	1143-0006	1143-0006	1143-0006	1143-0006	1143-0006
4	Drawer Assembly		4018-0031	4018-0031		4018-0031	4018-0031
5	Pedestal Assembly			6018-0039			6018-0039
6	Cabinet			4018-0016			4018-0016
7	Caster, Rigid			1277-0002			1277-0002
8	Caster, Swivel			1277-0001			1277-0001
9	Hot Cubby	6019-0024	6019-0024	6019-0024	6019-0024	6019-0024	6019-0024
10	Optical Light System	6007-0013	6007-0013	6007-0013	6007-0013	6007-0013	6007-0013
11	Work Positioner Assy.	6015-0028	6015-0028	6015-0028	6015-0028	6015-0028	6015-0028
12	Universal Mtg. Kit	6000-0141	6000-0141	6000-0141	6000-0141	6000-0141	6000-0141
13	Foot Pedal Assembly	6014-0006	6014-0006	6014-0006	6014-0006	6014-0006	6014-0006

REPLACEMENT PARTS

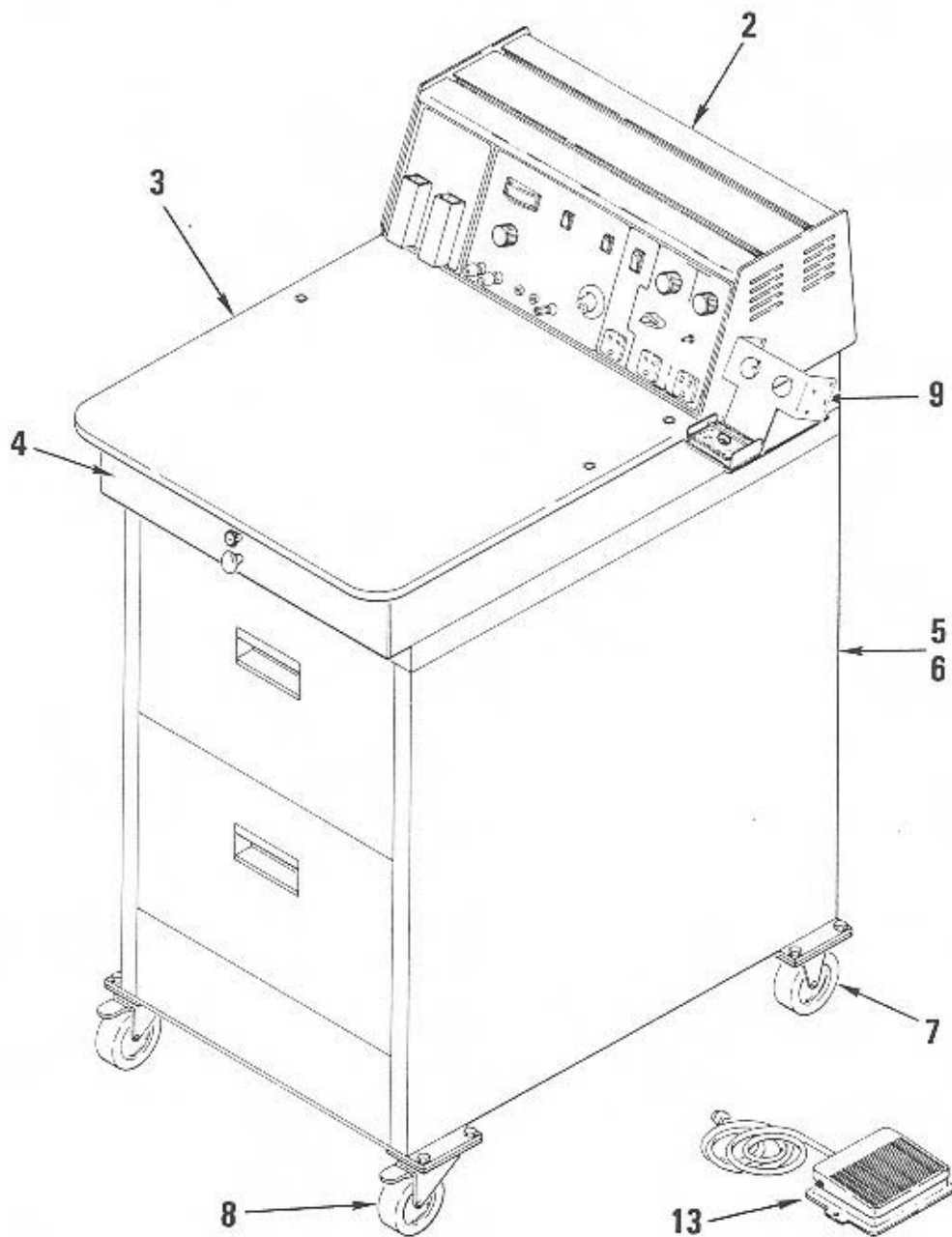

FIGURE 9. REPLACEMENT PARTS FOR PACE PRC351/E, 750/AE AND 1000/AE SYSTEM

REPLACEMENT PARTS

REPLACEMENT PARTS

When ordering replacement parts for your PACE PRC351/E, 750A/AE and 1000A/AE Console Series Repair System, refer to Table 7 and Figure 11 locating the desired part. Use the item number in Figure 11, then refer to Table 7 for that item number, part description and PACE part number.

**TABLE 7. LIST OF REPLACEMENT PARTS COMMON TO
PRC POWER SOURCE ASSEMBLY**

(Refer to Figure 11 for Item Number)

ITEM NO.	DESCRIPTION	PACE PART NUMBER	
		PRC351/750A/1000A	PRC351E/750AE/1000AE
1	PRC Power Source Assembly	7008-0159	7008-0160
	Chassis Assembly	6008-0107	6008-0110
2	Transformer Low Voltage	6000-0143	6000-0143
	Transformer Line Voltage	—	1192-0031
3	Motor/Pump Assembly	6008-0108	6008-0108
4	PC Board	6020-0036	6020-0036
5	Circuit Breaker (CB1, CB2, CB3)	1159-0240	1159-0240
6	Main Power Line Cord	1207-0151	1207-0151
7	Fuse (F1), 6.3A	1159-0118	1159-0221
8	Front Panel Assembly	6008-0106	6008-0109
9	Knob	1222-0021	1222-0021
10	Dual Heat Control	6020-0037	6020-0037
11	Variable Heat Control	1192-0003	1192-0003

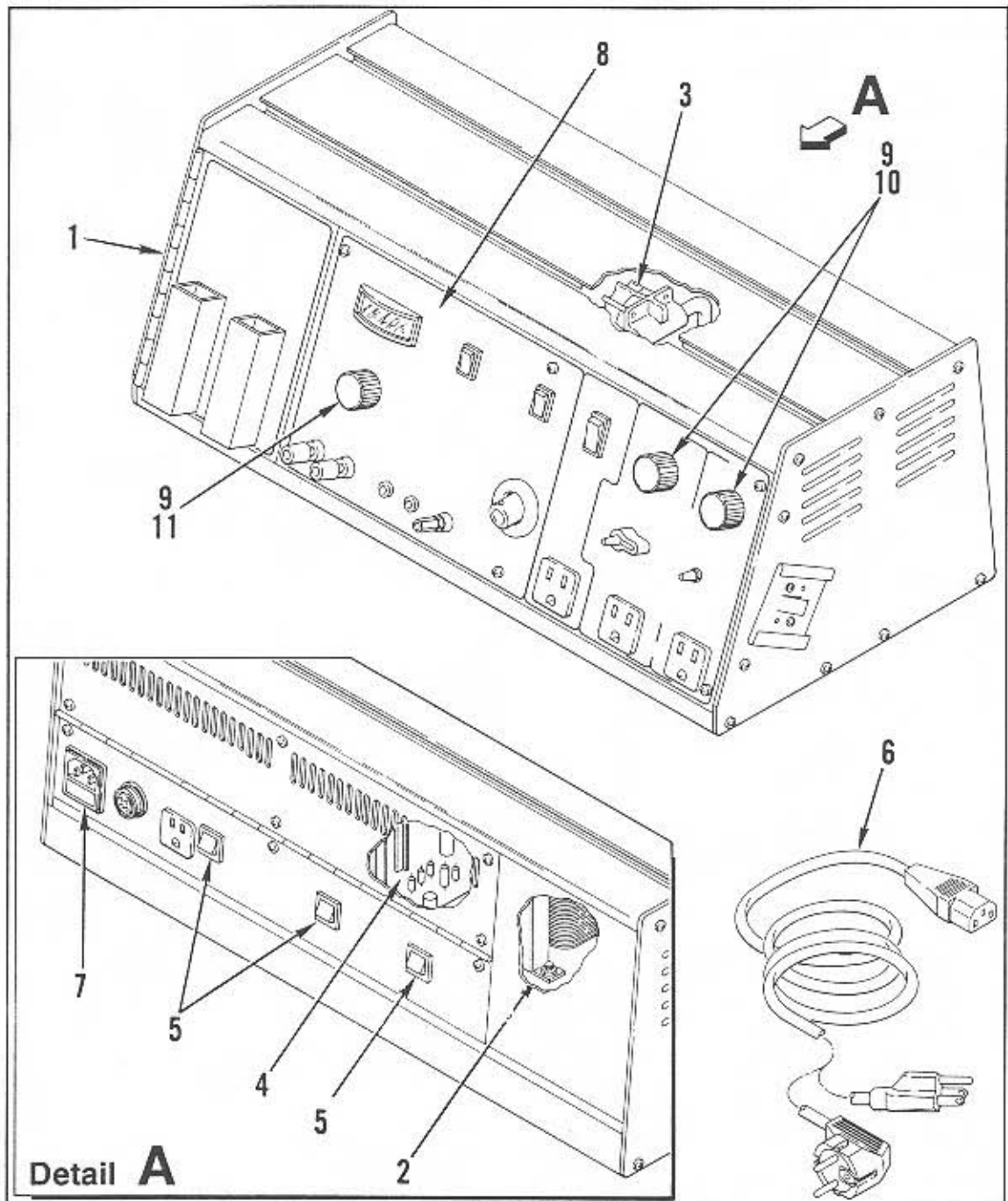

FIGURE 11. REPLACEMENT PARTS FOR PRC POWER SOURCE ASSEMBLY