

**ARM-EVAC<sup>®</sup> 250 & 200 SYSTEMS**

FUME EXTRACTION SYSTEMS



**OPERATION &**

**MAINTENANCE**

**MANUAL**

# **ARM-EVAC 250 & ARM-EVAC 200**

**MANUAL NO. 8881-0955**

**REV. A**

**APRIL 1999**

## **Warning**

Read the safety and applications information section in this manual thoroughly *before* installing and using your fume extraction system.



PACE Incorporated retains the right to make changes to specifications contained herein at any time, without notice.

Contact your local authorized PACE Distributor or PACE Incorporated to obtain the latest specifications.

The following are registered trademarks and/or servicemarks of PACE Incorporated, Laurel Maryland U.S.A. and may only be used to identify genuine PACE products or services:

Arm-Evac, Cir-Kit, ConducTweez, CRAFT, Flo-D-Sodr, Heat Wave, HotSpot, LapFlo, MBT, Micro Portable, MicroChine, MiniChine, Mini-Wave, PACE, Pacenter, Pik-Tip, PETS, Prep-Set, ResisTweez, SensaTemp, Snap-Vac, Sodr-Pen, Sodr-X-Tractor, ST, StripTweez, Thermo-Drive, ThermoFlo, ThermoJet, ThermoPart, ThermoPik, ThermoTweez.

The following are trademarks and/or servicemarks of PACE Incorporated, Laurel Maryland U.S.A. and may only be used to identify genuine PACE products or services:

Sodrtek, Toolnet



Since 1958, PACE Incorporated has provided advanced technology training in all aspects of hand soldering, rework and repair.

Additional copies of this manual or other PACE literature may be obtained from:

PACE Europe Ltd.  
Sherbourne House  
Sherbourne Drive  
Tilbrook  
Milton Keynes  
MK7 8HX Tel: (44) 01908 277666  
England Fax: (44) 01908 277777

PACE Incorporated  
Sales Administration  
9893 Brewers Court  
Laurel MD 20723-1990  
USA  
Tel: (301) 490-9860  
Fax: (301) 498-3252

©1999 PACE Incorporated, Laurel MD. All rights reserved. Printed in the U.K.

# TABLE OF CONTENTS

<b>TITLE</b>	<b>PAGE</b>
General Information .....	1
Use of this Manual .....	1
Introduction .....	1
Environmental Specifications .....	1
Central Filtration Unit .....	2
Safety and Applications .....	4
Installation .....	6
General .....	6
Configurations .....	7
Connecting One Or Two Flex Arms .....	7
Connecting One Or Two Bench Mounted Flex Arms .....	7
Connecting the 45mm (1.75") and 50mm (2") Static-Safe Metal Flex Arm .....	8
Operation .....	8
Arm-Evac 200 .....	8
Arm-Evac 250 .....	9
Self-Calibration Feature .....	9
Self-Calibration Procedure .....	9
Arm-Evac 250 Filter Condition Display .....	10
Optional Benchtop Controller for Arm-Evac 250 .....	10
Arm-Evac 250 RS232C Output for ISO 14000 Software .....	11
Maintenance .....	12
General Tips .....	12
Filter Replacement .....	12
Fuses .....	13
Motor .....	13
Accessories .....	13
Replacement Filters .....	14
Warranty .....	15

## TABLES

Table 1: Central Filtration Unit Specifications .....	2
Table 2: Replacement Filters .....	14

# GENERAL INFORMATION

## USE OF THIS MANUAL

This manual will provide the user with the basic knowledge to properly operate and maintain the PACE Arm-Evac 250 and Arm-Evac 200 Fume Extraction Systems. If you encounter any difficulty operating your system or have any questions, call your local authorized PACE dealer or contact PACE Applications Engineering directly at the United Kingdom Office at

Tel. (44) 01908 277666, Fax (44) 01908 277777, or PACE Product Management at the U.S. Office at Tel. (301) 490-9860, Fax (301) 604-8782.

### **Warning**

Read the safety and applications information section in this manual thoroughly *before* installing and using your fume extraction system.

## INTRODUCTION

The PACE Arm-Evac 250 and Arm-Evac 200 Fume Extraction Systems represent the latest technology in fume extraction. They feature a heavy-duty, maintenance-free brushless motor along with a filtration process that includes a pre-filter for coarse particle removal, and a High Efficiency Particulate Air (HEPA)/Gas Filter cartridge. The HEPA/Gas Filter is ideal for use in applications where high efficiency particulate removal is required with the additional benefit of a gas media blend to neutralize and adsorb noxious gases. Optional filters are also available.

The Arm-Evac 250 Fume Extraction System also incorporates an innovative filter condition monitoring system, a self-calibration feature and an RS 232 computer interface for computerized communication.

PACE Arm-Evac 250/200 Fume Extraction Systems use specially designed extraction accessories that can be conveniently mounted on any workbench or tabletop. The Arm-Evac 250 and Arm-Evac 200 systems are designed to extract fumes from one or two work stations.

## ENVIRONMENTAL SPECIFICATIONS

Ambient Operating Temperature:	0°C to 50°C (32°F to 122°F)
Storage Temperature:	-40°C to 125°C (-40°F to 257°F)
Ambient Operating Humidity:	90% relative humidity maximum non-condensing
Storage Humidity:	90% relative humidity maximum non-condensing

# GENERAL INFORMATION

## Central Filtration Unit

### Specifications

Arm-Evac 250 Systems		Arm-Evac 200 Systems	
System Part Numbers		System Part Numbers	
8889-0250 (230V)	8889-0255 (110V)	8889-0200 (230V)	8889-0205 (110V)
System Power Requirements		System Power Requirements	
220/240V, 50Hz, 1.3 amps	110V, 60Hz, 3 amps	220/240V, 50Hz, 1.3 amps	110V, 60Hz, 3 amps

### Specifications Common To All Arm-Evac 250 and Arm-Evac 200 Systems

<b>Weight:</b>	14.0 kg. (32 lbs.)	<b>Inlets:</b>	2 inlets, 75mm (3") dia.
<b>Size:</b> (Width X Depth x Height)	280 x 300 x 395mm (11 x 13 x 15.5 inches)	<b>Flow Rate With Dual Inlets:</b>	340 m3/h (200 cfm) [170 m3/h (100 cfm) per inlet]
<b>Housing:</b>	18 gauge steel with epoxy finish	<b>Flow Rate With Single Inlet:</b>	290 m3/h (170 cfm)
<b>Noise Level:</b>	59dBA at 2 meters (6.5 ft.)	<b>Motor Type:</b>	Single Stage Centrifugal
<b>Pre-Filter:</b>	Part Number 8883-0111-P5 Multi-Stage Polyester Media, 254 x 254 x 178 mm (10 x 10 x 7 inches)		
<b>Combo HEPA/Gas Filter:</b>	Part Number 8883-0931 HEPA filter composed of borosilicate media . Gas filter composed of chemisorptive and adsorptive media blend.		

### Arm-Evac 250 Supplemental Specifications

<b>Filter Condition Gauge:</b>	Five (5) color LED display
<b>Filter Condition Pressure Sensor:</b>	Laser trimmed thick film ceramic with integrated circuitry
<b>Filter Condition Calibration:</b>	Sequential multi-point self-calibration for zero and span levels
<b>Fan Speed Control:</b>	Front-panel mounted on/off with integral three-speed (3) variable switch
<b>Calibration Lockout:</b>	Tamperproof keyed switch
<b>Outputs:</b>	Remote control and RS232C communication ports

Table 1: Central Filtration Unit Specifications

# GENERAL INFORMATION

- |  |                              |                               |
|--|------------------------------|-------------------------------|
| ① Filter Access Cover                        | ⑥ Motor Pump                 | ④ Power Receptacle            |
| ② Inlet Ports                                | ⑦ Front Panel                | ⑤ Fuse & Fuse Holder          |
| ③ Pre-Filter                                 | ⑧ Rubber Foot                | ⑥ Power Switch                |
| ④ Cover Latch                                | ① Exhaust Port               | ⑦ 3-Speed Flow Control Switch |
| ⑤ General Purpose Filter or Optional Filters | ② REMOTE Connector           | ⑧ Keyed Switch                |
|  | ③ PC COMS Connector (RS232C) | ⑨ Filter Condition Display    |

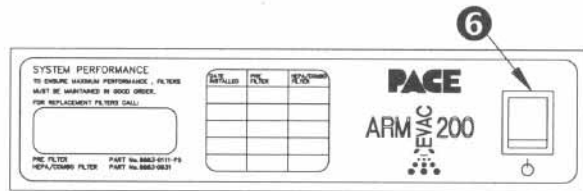
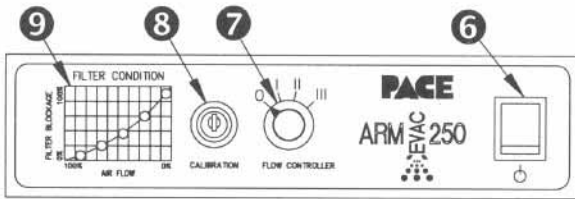
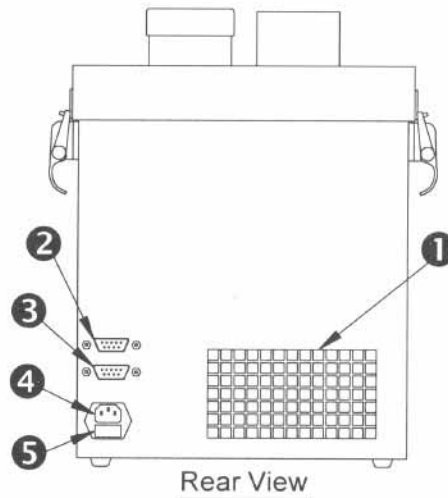
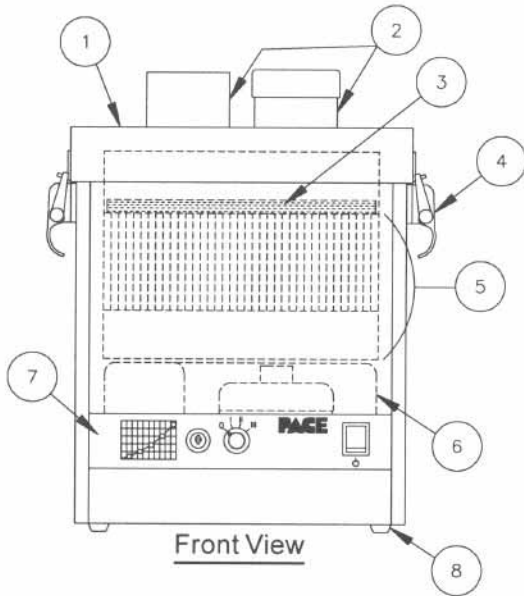

PACE Arm-Evac 250/200 Parts Identification

## **SAFETY AND APPLICATIONS**

PACE Fume Extraction systems are designed to reduce the level of harmful contaminants from the work environment and to assist in the achievement of recommended health and safety requirements for local exhaust ventilation and contaminant removal. Be sure to follow all Application and Maintenance guidelines contained herein and precautions contained in other relevant product safety literature (i.e., Material Safety Data Sheets) provided with the substances and equipment producing the fumes to be extracted.

### **DISCLAIMER**

PACE hereby disclaims all responsibility for any personal injury, property damage, fine, citation or penalty imposed by any government or private entity which results from any use, misuse or mis-application of this product, failure of the user to regularly maintain the product according to the recommended guidelines, or failure to adequately monitor fume extraction exhaust air and the ambient workplace air for the presence of harmful levels of gases, fumes and particulates.

Compliance with all applicable environmental and personnel safety regulations is the sole responsibility of the user and adequate self-monitoring of exhaust air released into the atmosphere or the workplace as well as monitoring of the ambient workplace air is strongly recommended. To insure continued effective performance, the following guidelines must be followed.

### **SAFETY**

#### **DANGERS**

1. PACE Fume Extractors are not intended to be used as a substitute for devices such as personal protective respirators which are designed to remove poorly adsorbed substances including carbon monoxide, methane, hydrogen, acetylene and other gases. Risk of serious injury or death, fire or explosion may result from improper use. If in doubt, consult with your industrial hygienist or PACE.
2. Never use PACE Fume Extraction Systems to extract fumes from highly flammable liquids and gases such as Ether, Gasoline (Petrol) and others. Risk of serious injury, death, fire or explosion may result.
3. High concentrations of airborne contaminants such as Methyl Ethyl Keytone, Cyclohexone, Ozone and others, when contacted with activated carbon, can undergo oxidation, decomposition or polymerization resulting in exothermic reactions or heat generation. PACE Fume Extraction Systems must not be used to extract fumes from these substances when high concentrations are present.
4. Failure to comply with the application and maintenance guidelines, filter replacement schedules, monitoring recommendations and safety guidelines contained herein and in other relevant product safety literature (i.e., Material Safety Data Sheets) provided with the substances and equipment producing the fumes to be extracted could result in risk of serious injury, fire or explosion.

#### **WARNINGS**

1. Do not attempt to clean any PACE fume extraction filters for reuse. Cleaning the filters will severely damage the filter media and, consequently, the filter's performance. This will result in unfiltered, contaminated air being returned to the working environment. Unfiltered air can also damage the motor pump.



## SAFETY AND APPLICATIONS

2. Use with inappropriate chemicals or substances, failure to provide regular maintenance or other misuse of your Fume Extraction System may result in contaminated air being recirculated into the work environment.

### CAUTIONS

1. Failure to supply the correct voltage to the unit will result in damage to the motor.

### NOTES

1. To ensure the highest level of performance, use only PACE replacement filters in your PACE Fume Extraction System.
2. BE SURE the new filter cartridge is installed with the airflow arrow pointing downward.

### FILTER CARTRIDGE NOTES

PACE Fume Extraction Systems are equipped with filters designed to capture particulates and noxious gases and odors that are present in the air being filtered. The Fume Extraction systems are equipped with combinations of pre-filters for coarse particle removal, HEPA filters for fine particle removal, and gas filter media to remove gaseous compounds. Over time, the HEPA filter will gradually become clogged, impeding air flow through the system, and the capacity of the gas filter will be reached, reducing its ability to continue to neutralize and adsorb noxious gases and odors.

Filter Cartridges **must be replaced at regular intervals** to ensure that the fume extraction system is operating effectively. These intervals will vary depending on the type of work being performed, the level of use, and the amount and composition of airborne contaminants produced.

The exhaust air stream from the central filtration unit as well as the ambient air in the workplace should be monitored with appropriate and adequate measuring/detection devices to assure compliance with all applicable Health and Safety regulations.

Flammable vapors and gases (i.e. Isopropyl Alcohol) are removed by and accumulate in the gas portion of the Filter Cartridge presenting a potential fire hazard. Therefore, the user must exercise appropriate precautions when extracting such fumes or when handling and disposing of filters containing such flammable substances. Follow *all fire safety and personnel protection guidelines* contained in the Material Safety Data Sheet (MSDS) for the substance(s) producing the extracted vapors and gases (fumes).

When disposing of used filters, extreme care must be taken to comply with *all* applicable environmental regulations. Carefully consult the MSDS supplied with the material(s) producing the fume. If in doubt, check with your local Environmental Authority.

Extreme care must be exercised when disposing of a used Filter Cartridges containing potentially hazardous substances. When disposing of filters, appropriate and adequate personal protective equipment (i.e. gloves, respirators, plastic containment bags, etc.) must be used when hazardous substances such as asbestos, lead, radioactive or biohazard materials may be present. Consult the Material Safety Data Sheet (MSDS) of the materials generating the extracted fume.

# INSTALLATION

## GENERAL

The Arm-Evac 250 and Arm-Evac 200 have been designed with maximum installation flexibility in mind. A number of configurations may be used. (See the “Configurations” section.) The following are recommended guidelines for setting up your system. If you have any specific questions that this section does not cover please consult your PACE Representative or call PACE directly.

### **1. Placement**

There are 3 major considerations that need to be addressed for proper placement of the central filtration unit.

- **Exhaust Port:** This is located on the back of the filtration unit, next to the power inlet. When positioning the unit, make sure that the exhaust port is *not* blocked or that airflow from the exhaust port is not restricted in any way.
- **Unit Location:** The filtration unit should be positioned so that it will not block aisleways or impede normal operating traffic or material handling pathways. It is important to position the unit to allow for proper clearance to remove the filter access cover and replace the filter as needed.
- **Proximity to the work area:** The filtration unit should be placed as close to the work area as possible. If using a flex hose, it is advantageous to keep the length of flex hose as short as possible. **Do not** kink or create any sharp bends in the flex hose, as this will reduce airflow.

### **2. Power**

The Arm-Evac 250/200 will plug into a standard 110 volt or 230 volt electrical outlet, depending on the model you purchased. A line cord is provided with each system. Be sure the unit you have is rated for the intended power supply.

<b>Caution</b>
Failure to supply the correct voltage to the unit will result in damage to the motor.

### **3. Self-Calibration Procedure**

<b>IMPORTANT</b>
This procedure must be performed on the Arm-Evac 250 before initial operation.

### **4. Filters**

Before operating the unit, make sure the filters are correctly positioned. The pre-filter is always located on top, and the direction of airflow is clearly marked on the filter cartridge. Airflow is always in a downward direction for the Arm-Evac 250/200.

### **5. Inlet Caps**

If an inlet port is not connected to a collection device, it must be covered with the inlet cap provided.

# INSTALLATION

## 6. Accessories

The Arm-Evac 250/200 is designed to be used with *one or two* collection accessories (i.e. flex arm, articulated arm, plenum, etc.). When using two collection devices, *any two* may be used together. This provides maximum flexibility in meeting the fume extraction needs in your work environment. Performance can only be guaranteed when using genuine PACE Fume Extraction collection accessories.

## CONFIGURATIONS

### Connecting One or Two Flex Arms

- 1) Slide the narrow end of the Flex Arm (P/N 8886-0365) over one inlet port on the Arm-Evac 250/200.
- 2) Secure the Flex Arm to the inlet of the Arm-Evac with the Flex Arm clamp (provided).
- 3) Position the Flex Arm for maximum extraction performance.
- 4) If using one Flex Arm, make sure the inlet cap covers the unused inlet.
- 5) Repeat steps 1 through 3 to attach second Flex Arm.

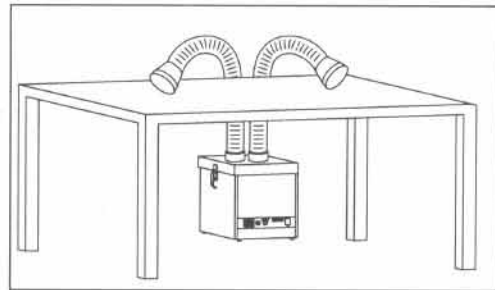

Arm-Evac fitted with two Flex Arms

### NOTE

The Arm-Evac 250/200 can be placed on the benchtop or located under a workbench, depending on operator preference.

### Connecting One or Two Bench Mounted Flex Arms

- 1) To mount the Flex Arm to a bench or tabletop, the optional Bench Mounting Kit (P/N 8886-0363) is required.
- 2) Position the bench mounting bracket on the tabletop and secure it with the two screws provided.
- 3) Slide one end of the flex hose over an inlet port on the Arm-Evac and secure it with a hose clamp (provided).
- 4) Connect the other end of the flex hose to the bottom of the bench mounting bracket and secure it with the other hose clamp.
- 5) Slide the Flex Arm over the top of the bench mounting bracket and secure it to the bracket with the Flex Arm clamp (provided).
- 6) Position the Flex Arm for maximum extraction performance.
- 7) If using one Flex Arm, make sure the inlet cap covers the unused inlet.
- 8) Repeat steps 1 through 6 to attach second arm.

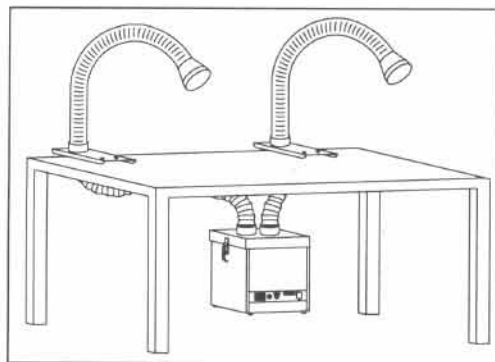

Flex Arms with Bench Mounting Kits

# INSTALLATION

## Connecting the 45mm (1.75") and 50mm (2") Static-Safe Metal Flex Arms

- 1) Attach the Static-Safe Metal Flex Arm (either size) at a convenient location on the workbench either permanently or with the bench mounting bracket (P/N 8886-0552).

Permanent Mounting: The extraction arm can be permanently mounted to a workbench or tabletop.

- A.) Drill a 50mm (2") diameter hole in the workbench.
- B.) Locate the Static-Safe Metal Flex Arm flange in the hole and mark the position of the 4 holes in the mounting flange. Remove the Static-Safe Metal Flex Arm and drill the 4 marked areas with a 2mm (3/32") drill. Refit the Static-Safe Metal Flex Arm. Secure the mounting flange to the workbench with the 4 mounting screws (supplied).

Portable Bench Mounting: The Static-Safe Metal Flex Arm can be bench mounted with the bench mounting bracket (P/N 8886-0552).

- A.) Open the bench mounting bracket butterfly screw, position the bracket over the edge of the work bench, then tighten the butterfly screw until the bracket is securely mounted on the work bench.
  - B.) Install the Static-Safe Metal Flex Arm to the bench mounting bracket with the 4 mounting screws (supplied).
- 2) Position the Static-Safe Metal Flex Arm as needed. The Arm can be repositioned simply by grasping the Static-Safe Metal Flex Arm above the fume scoop and moving it to the desired location.
  - 3) Connect the flexible hose (P/N 8886-0299) to the inlet port of the Arm-Evac 250/200 and secure it with the hose clamp (provided). Connect the other end of the flex hose, with the reducer, to the inlet of the Static-Safe Metal Flex Arm.
  - 4) If only one inlet port on the Arm-Evac is used make sure the unused inlet port has its cap in place.
  - 5) Repeat steps 1 through 4 to install additional Static-Safe Metal Flex Arms.

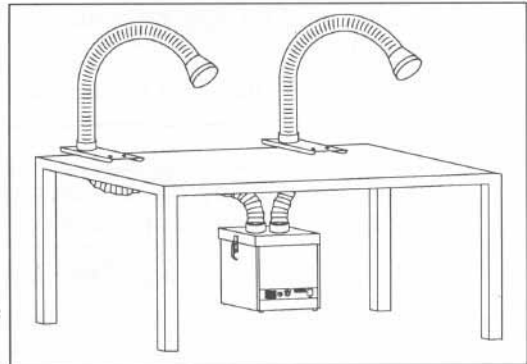

*Metal Flex Arms With Bench Mounting Kits*

## ARM-EVAC 200

As the system is used, the filter will eventually become clogged with collected particulates. If air flow is insufficient to collect the fumes, the filter(s) should be replaced. Refer to "Filter Replacement", page 12.

- 1) Turn the power switch to the On ("I") position.
- 2) Position the Arm-Evac accessory in a convenient and effective extraction location.

## ARM-EVAC 250

### Self-Calibration Feature

The Arm-Evac 250 contains advanced microprocessor-based sensing technology which allows for self-calibration of the filter condition monitor by establishing clean filter air flow conditions (that is, 0% filter blockage) and fully clogged filter flow conditions (that is, 100% filter blockage). Further, this procedure insures that the air flow sensing process is consistent with and particular to the accessory configuration array and filters being used.

### Self-Calibration Procedure

#### NOTE

**This procedure must be performed on the Arm-Evac 250 before initial operation, whenever a filter changeout occurs and whenever a change in system configuration occurs. DO NOT make any adjustments to the accessory configurations during calibration as this will disrupt the self-calibration process.**

- 1) The normal operating position of the Keyed Switch (item ⑧) is in a vertical position.
- 2) The Keyed Switch is supplied with 2 identical keys. To start the self-calibration procedure, insert the key into the switch. Turn the Keyed Switch 1/4 turn clockwise (from normal vertical position).
- 3) Turn the Power Switch (item ⑥) to the On ("I") position (Green switch light illuminates). An audible single beep followed by a double beep signals initiation of the self-calibration procedure. The LED lights will sequence from Green to Amber to Red on the Filter Condition Gauge (item ⑨) several times. There is no need to adjust the 3 position Speed Controller (item ⑦); the self-calibration mode over-rides the controller.
- 4) The Self-Calibration procedure will require a running time of approximately 2 minutes in order to establishing clean filter air flow (0% filter blockage) levels for all three speed settings as well as fully clogged filter levels.
- 5) When the far right LED remains illuminated, the self-calibration procedure is complete. To initiate normal operation, turn the Keyed Switch 1/4 turn counter-clockwise. The Red LED will turn off and the Green LED will illuminate and normal operation will resume. Adjust the 3 position Speed Controller (item ⑦) as necessary. To assure tamperproof operation, the key can be removed from the switch.
- 6) Daily operations can be initiated by simply turning the Power Switch (illuminates Green when On) to the "On" ("I") position and setting the 3 position Speed Controller (item ⑦) to the appropriate position. A single beep will sound when the Arm-Evac 250 is turned on.

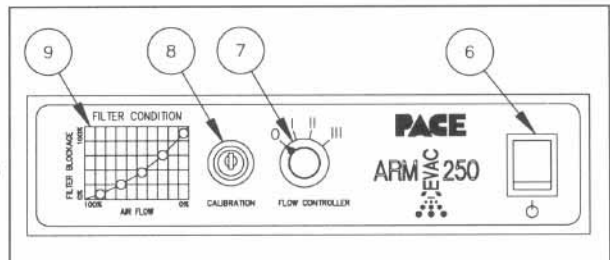

# OPERATION

## Arm-Evac 250 Filter Condition Display

The Arm-Evac 250 has a graphical Filter Condition Display which continuously monitors filter condition. As the system filter(s) collect particulates, LEDs on the Filter Condition Display will illuminate along the graphical curve of the display.

Initially, a Green LED will illuminate (at bottom of graph). As the air flow rate decreases (as the filter(s) start to become clogged), LEDs will illuminate high on the graphical curve.

Illumination colors will darken to shades of Yellow and finally to Red as the illumination reaches the top of the graphical curve.

When the first Red LED illuminates, it is indicating insufficient air flow. Replacement of the filter(s) at this point is highly recommended. Refer to "Filter Replacement", page 12.

If the last Red LED (at the upper right of display) illuminates, an alarm will sound. **Immediately**, turn system power off (Power Switch) and change filters.

### CAUTION

Overheating may occur and cause motor damage if the system is operated with completely clogged filters.

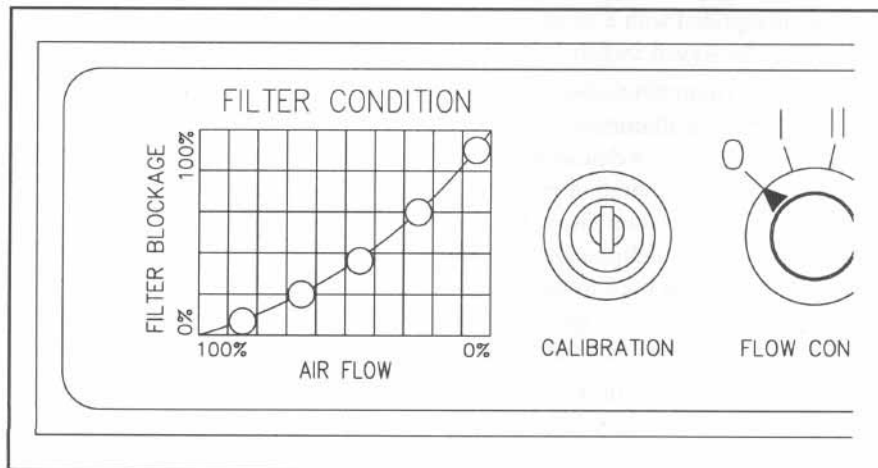

## Optional Benchtop Controller for Arm-Evac 250

An optional Benchtop Controller (P/N 8884-2250) is available for the Arm-Evac 250 to enable convenient access to the three speed flow control switch (refer to item ②, next page), and surveillance of the filter condition display (refer to item ①, next page).

## Setup/Operation

Use the following procedure to set up and operate the Remote Control. Refer to illustration below.

- 1) Attach the end of the Benchtop Controller Cable identified as "250" to the connector located on the back of the Arm-Evac 250 identified as "Remote". Refer to illustration below.
- 2) Attach the end of the Benchtop Controller Cable identified as "REM" to the connector located on the Benchtop Controller (item ③).
- 3) Position the Benchtop Controller in convenient location.
- 4) Once the cables are connected, assume normal operating procedures.

### NOTES

Once connected to the Arm-Evac 250, the Benchtop Controller will over-ride all controls with the exception of the keyed calibration switch and Green lighted Power Switch.

If the self-calibration procedure is initiated while the Benchtop Controller is connected, the LED Display on the Benchtop Controller will mimic the filter condition gauge (refer to item ①) as identified in the "Arm-Evac 250 Self-Calibration Procedure".

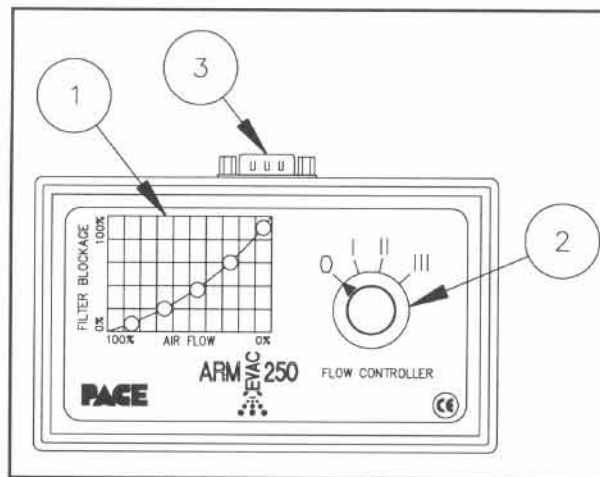

## Arm-Evac 250 RS232C Output for ISO 14000 Software

The Arm-Evac 250 has a microprocessor integral with its electronic control circuitry which can transfer data to support ISO 14000 documentation requirements. The output connector (marked "PC COMS ") on the back of the Arm-Evac 250 and cable connection provides a communication link for transfer and storage of data to a computer.

Contact your local PACE representative or contact PACE directly to obtain detailed operating instructions.

# MAINTENANCE

## GENERAL TIPS

- Before opening the Arm-Evac, always turn off the power source.
- Protect the Arm-Evac and accessories from dampness.
- Do not extract water vapor or steam.
- The Arm-Evac must not be used without filters. Impurities in the extracted air can damage the motor pump.
- Do not allow the Arm-Evac or ducting hoses to become blocked.
- Do not extract corrosive compounds without checking with PACE.
- Recalibrate the Arm-Evac 250 whenever a filter change or system configuration change occurs.

## FILTER REPLACEMENT

### **Pre-Filter**

This filter removes coarse particles from the air. In general, the pre-filter must be changed on a monthly basis. However, depending on your particular process, the filter may need to be changed more or less frequently. A visual inspection on a weekly basis is recommended.

### **Main Filters**

Fume extraction filters remove particulates from the air and capture noxious odors and gases. Depending on your particular process, the filter cartridge may need to be changed more or less frequently.

### **Replacement Procedure**

- 1) Turn Power Switch to the Off ("0") position.
- 2) Remove the Filter access cover.
- 3) Remove the old Filter cartridge (or cartridges).
- 4) Install a new Filter (or filters).  
On the Arm-Evac 250, insure that the Pressure Tube (black-coiled cable inside filter compartment) does not become kinked when the new Filter is installed.
- 5) Replace the Filter access cover.
- 6) Dispose of used Filters properly.
- 7) **Arm-Evac 250 Systems Only:** Recalibrate according to Self-Calibration Procedure (see Page 9).
- 8) Turn Power Switch to the On ("1") position.

#### **Important**

BE SURE the new filter cartridge is installed with the airflow arrow pointing downward and Pressure Tube does not become kinked.



## FUSES

The fuse is located in a sliding tray on the back side of the Arm-Evac 250/200, just below the power receptacle. Each Arm-Evac is supplied with one replacement fuse, also located in the sliding tray.

Replacement fuses are available for the Arm-Evac 250/200 systems in packages of 5 fuses.

**230 VAC systems** (part numbers 8889-0200 and 8889-0250) come standard with a 3.15 amp fuse, part number **8884-9966-P5**.

**110 VAC systems** (part numbers 8889-0205 and 8889-0255) come standard with an 8 amp fuse, part number **8884-9961-P5**.

## MOTOR

Fume Extractor Motors are maintenance-free, brushless single inlet fans which do not require routine maintenance. It is important that fume extractor filters are changed on a regular basis to protect the motor impellers from pollutants.

## ACCESSORIES

Monthly cleaning of the Arm-Evac 250/200 extraction accessories is recommended. Arm-Evac accessories should be cleaned with a non-aggressive cleaning solvent or detergent only. Make sure the Arm-Evac accessories are completely dry before reuse.

## REPLACEMENT FILTERS

### REPLACEMENT FILTERS

Item #	Name	Description	Typical Applications	Part Number
1	Arm-Evac 250/200 Pre-Filter	Designed for coarse particle capture.	Used with all Arm-Evac 250/200 systems.	8883-0111-P5 (Pkg. of 5)
2	Arm-Evac 250/200 General Purpose Filter	Comprised of HEPA filter media & gas blend media.	Soldering, Pharmaceuticals Laser Cutting/Laser Marking Jewelry manufacturing & repair.	8883-0931
3 *****	Arm-Evac 250/200 Extended Life Pre-Filter (optional item)	Designed for coarse particle capture.	Heavy-duty soldering operations.	8883-0938-P10 (Pkg. of 10)
4 *****	Arm-Evac 250/200 Extended life Combo HEPA/Gas Filter (optional item)	Comprised of HEPA filter media & gas blend media.	Heavy-duty soldering operations.	8883-0936
5	Adhesives Filter (optional item)	Blend of Adsorptive and Chemisorptive media.	Benchtop Adhesives Procedures Gluing Applications Circuit Board Cleaning Laboratory Applications	8883-0951
6	Cleanroom Filter (optional item)	Comprised of HEPA filter media & bonded activated carbon.	Fine particulate and gas removal in designated Cleanroom environments.	8883-0921
7	Economy Foam Filter (optional item)	Carbon-Impregnated Reticulated Foam Media. Designed for coarse particle capture.	Sanding Applications Benchtop Machining Operations Benchtop Prototyping Operations Grinding Applications	8883-0871

Table 2: Replacement Filters

\*\*\*\*\* **NOTE** - The Arm-Evac 250/200 Pre-Filter and Combo HEPA/Gas Filter (items 3 and 4 in the table below) must be used together. **NEVER** use them separately!